



NEXT
ORE

KANSANSHI MINE

CASE STUDY

BULK ORE SORTING USING
MAGNETIC RESONANCE SENSING

nextore.com.au

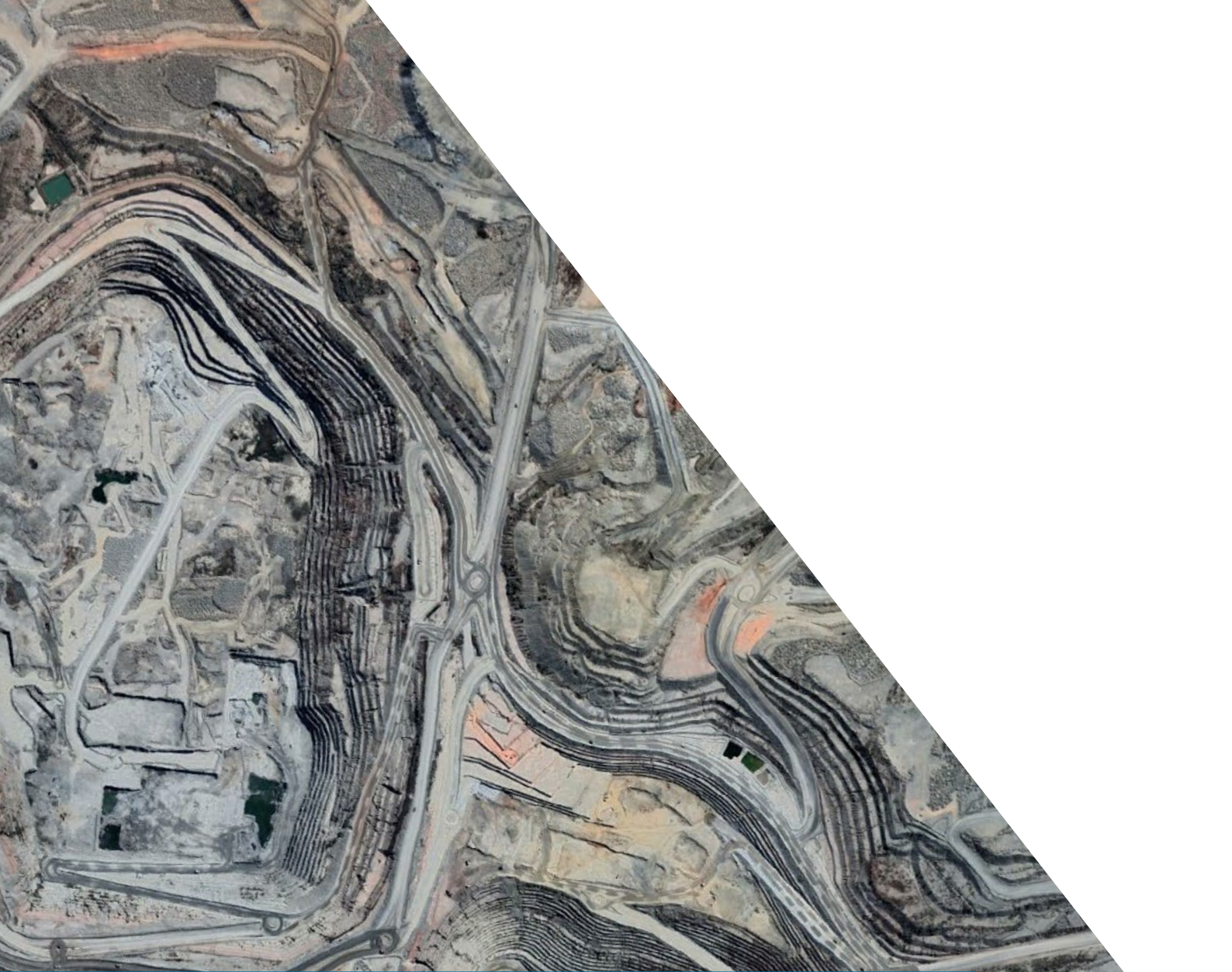

The Kansanshi mine (100% First Quantum Minerals “FQM”) is located in the North-Western Province of Zambia. Kansanshi has an extended history of operation, with the modern mine being established by FQM in the early 2000’s.

INTRODUCTION

Sensor based bulk ore sorting (“BOS”) is an emerging mining technology with the ability to deliver a combination of improved revenues, decreased costs and reduced environmental impact for mining operations.

These outcomes are achieved by preconcentrating desirable economic minerals in process plant feed using a simple, capital efficient assembly of equipment. This equipment effectively increases the metal production from capital processing equipment and reduces consumption of electricity, water and reagents that would have been wasted on processing of barren material.

In some circumstances, BOS equipment can be retrofitted to the infrastructure of existing mining operations. This paper presents a case study of successful bulk ore sorting (BOS) at the Kansanshi mine. BOS effectiveness was confirmed and validated at a rate of 2,800 tonnes per hour, with measurements of mineralogical grade provided at intervals of 4 seconds corresponding to 3.1 tonne pods using a magnetic resonance analyser (MRA).

This case study focuses on the technical and operational aspects a BOS retrofit project.

Main topics

- Bulk sorting plant design
- Retrofitting design considerations
- Analyser selection criteria
- Validation procedure
- Sorting performance (mass flow and recovery).



KANSANSHI MINE

Mining

Mining at Kansanshi is by conventional open pit mining using shovel and truck mining techniques.

Ore types, corresponding to independent processing streams in the Kansanshi mineral processing plant, are categorized as sulphide, oxide and mixed.

The metallurgical processing system is designed to operate with a high degree of flexibility to suit the various ore types received. As a result, there are three main processing routes, with independent dump stations and crushers, which feed corresponding processing circuits.

The flexible design of the process plant allows ores to be treated through any of the three circuits which allows balancing of tonnages as each circuit has different capacities.



Geology and Mineralogy

Copper mineralisation at Kansanshi occurs as three deposits (Main, North West and South East). The deposits are located within domal structures along the crest of a regional antiform. Deposit mineralisation is closely associated with these domes.

Three styles of primary sulphide mineralisation are associated with these deposits:

- Disseminated stratabound mineralisation
- Sub-vertically dipping, quartz-carbonate-sulphide veins crosscutting the stratigraphy
- Localised breccia mineralisation.

Weathering influences mineralisation as follows:

- Near surface weathering in the saprolitic zone
- Around vertical veins, with oxide copper mineralisation predominantly evident as malachite, tenorite and chrysocolla
- Mixed primary and secondary sulphide copper mineral assemblages in transitional zones between weathering zones
- Pervasive shallow to deep weathering located along geological structures.

Primary sulphide copper mineralisation is mostly chalcopyrite, with minor bornite. Oxide mineralisation is mostly chrysocolla with malachite. The transition zone contains mixed oxide, primary sulphide, secondary chalcocite and minor native copper and tenorite. Minor copper is hosted in clay and mica minerals, and is classified as refractory. Gold is associated with copper mineralisation.

(Gray, Lawlor, & Briggs, 2020)

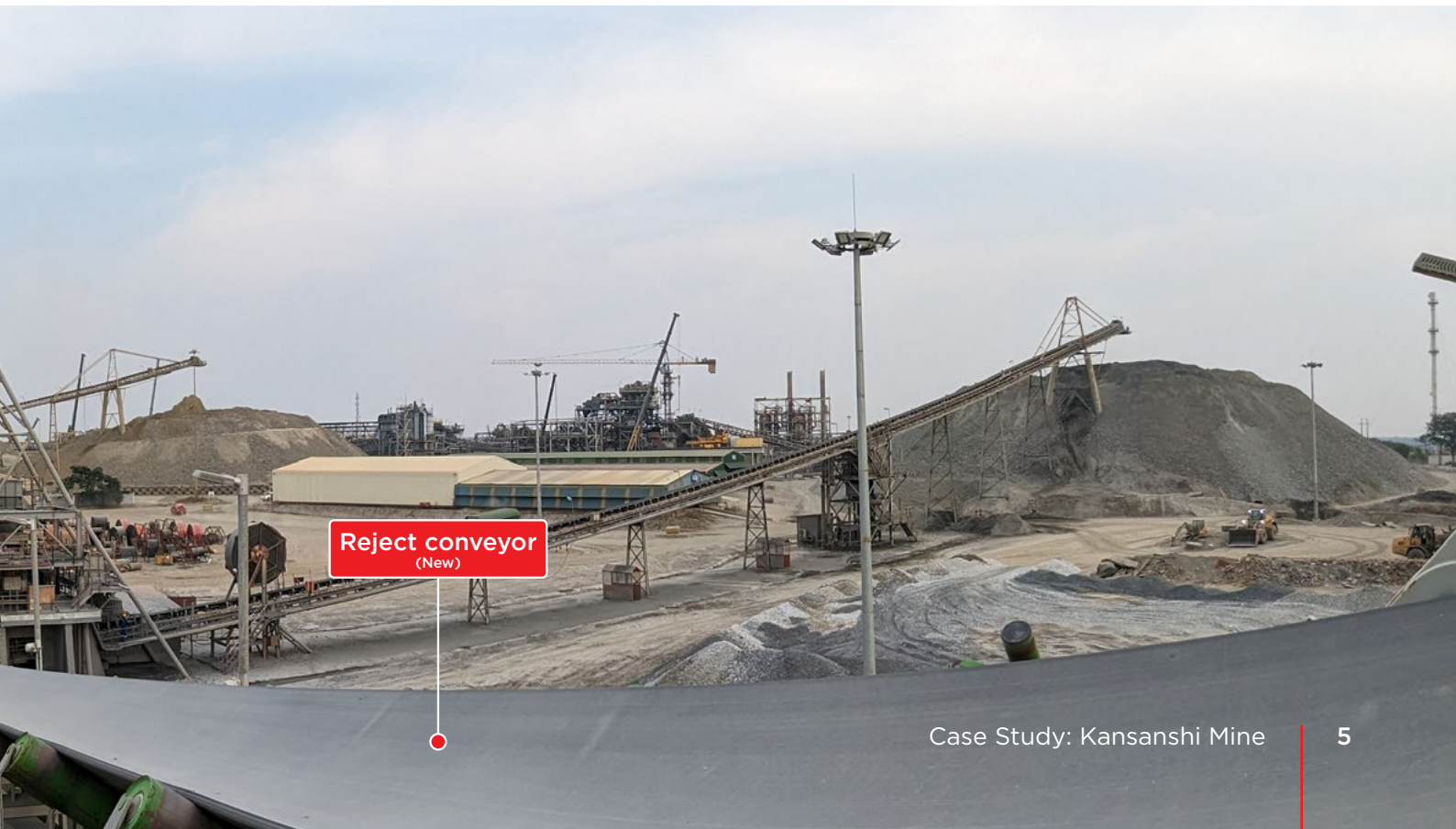

Reject conveyor
(New)

BULK SORTING EQUIPMENT CONFIGURATION

Shown in Figure 1, the BOS equipment is retrofitted to the existing primary sulphide crushing circuit, comprising of primary gyratory crusher and secondary cone crusher feeding to the coarse ore feed stockpile for the sulphide circuit, along with associated feeders, conveyors, and transfer chutes. The BOS equipment to be retrofitted would include:

- MRA configured for chalcopyrite grade measurement, and
- Reject conveyor belt discharging to stockpile.

Modifications of existing equipment would include:

- Addition of hydraulically actuated rock box diverter to a chute.

Retrofitting to Existing Crushing Circuit

The existing layout of the KMP primary sulphide crushing circuit presented a favourable opportunity for retrofitting of BOS system. CV-1201 receives primary crushed ore from a gyratory crusher and discharges to a tower fitted with secondary cone crusher, shown in Figure 2. This tower contains transfer chutes which could be modified and upgraded with a customised diverter to enable bulk ore sorting with minimal impact on production. Sufficient clear area to the Northwest of the transfer tower was able to easily accommodate both a reject handling conveyor belt and stockpile. Satellite imagery in Figure 3 shows the area before and after BOS installation.

Figure 2 - Kansashi S2 primary gyratory crusher (far right), discharging to CV-1201, transfer tower and cone crusher (centre) discharging to coarse ore grinding feed stockpile (left). Photo taken prior to analyser and bulk sorting retrofit.



PROCESS FLOW DIAGRAM

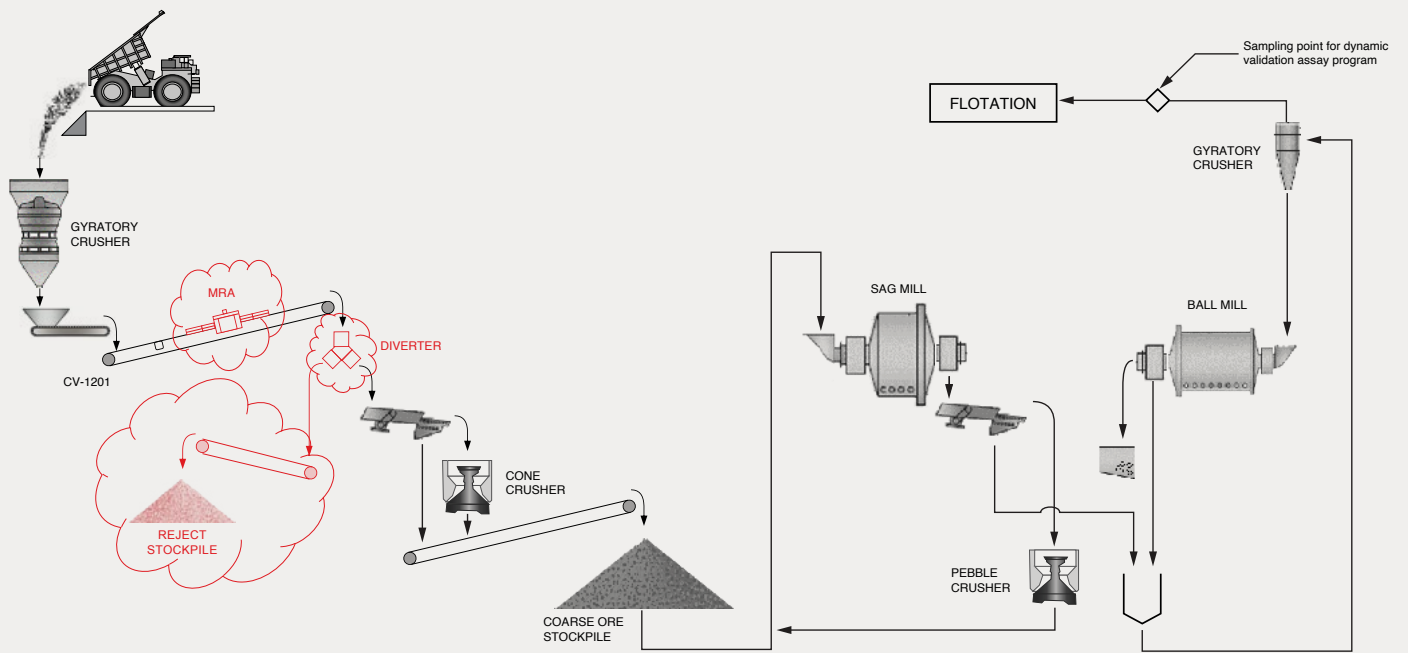

Figure 1 – Process flow diagram of existing KMP primary sulphide crushing and grinding circuit with retrofitted BOS equipment shown in revision clouds and the sampling point for the dynamic validation test indicated (top right).





Figure 3 - Satellite image of Kansashi sulphide primary crushing circuit in August 2021 (left) and June 2022 (right), after installation of BOS equipment.



Magnetic Resonance Analyser

The sensor-to-diverter time interval is crucial for any BOS system. It must be at least the measurement pod duration + processing time + half the diverter actuation time. Limited placement on CV-1201 forced installing the MRA 46 meters from the feed end, leaving 67 meters to the discharge point (Figure 4). The short measurement interval achievable using magnetic resonance adds to the flexibility of the system. The 4-second measurement interval in fact allows four pods are fully measured before discharge and is more than adequate.

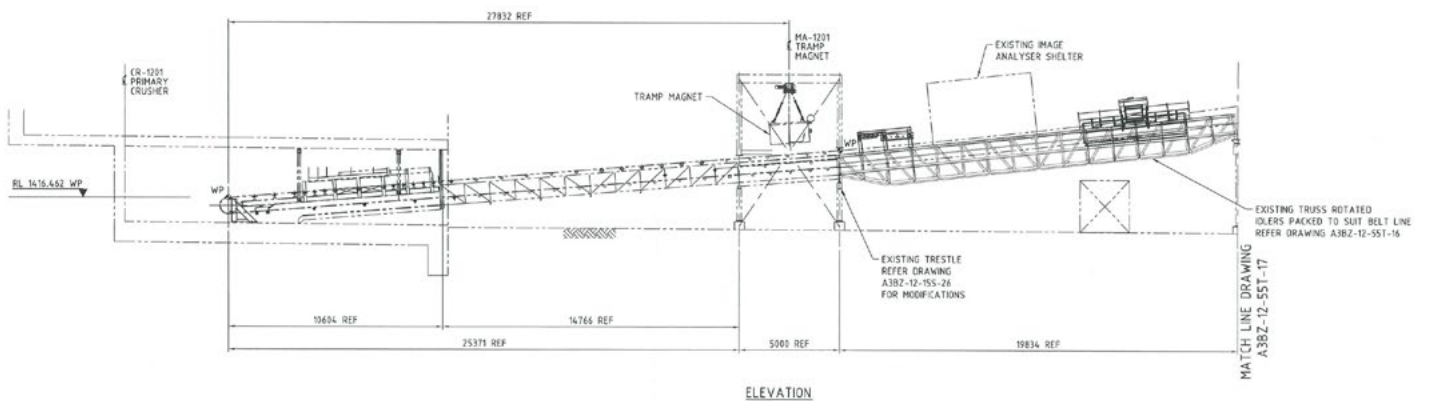

Figure 4 - CV-1201 Elevation showing selected MRA installation position relative to feed end.

MRA Design Considerations

MRAs comprise two primary components, the electronics container and the sensor. The electronics container is an air-conditioned shipping container, 10 or 20 feet in length, and houses the radiofrequency power supply, amplification, conditioning and control systems. The electronics is positioned within 10m of the sensor and connected by several cables.

The sensor is an approximately cylindrical shaped radiofrequency antenna, constructed in upper and lower halves, through which the conveyor belt passes. MR sensors are customised to suit the dimensions of the existing conveyor and the ore. The 600-800kg sensor assembly is designed to rest on the existing conveyor belt structure without modification and without the need to cut the conveyor belt.

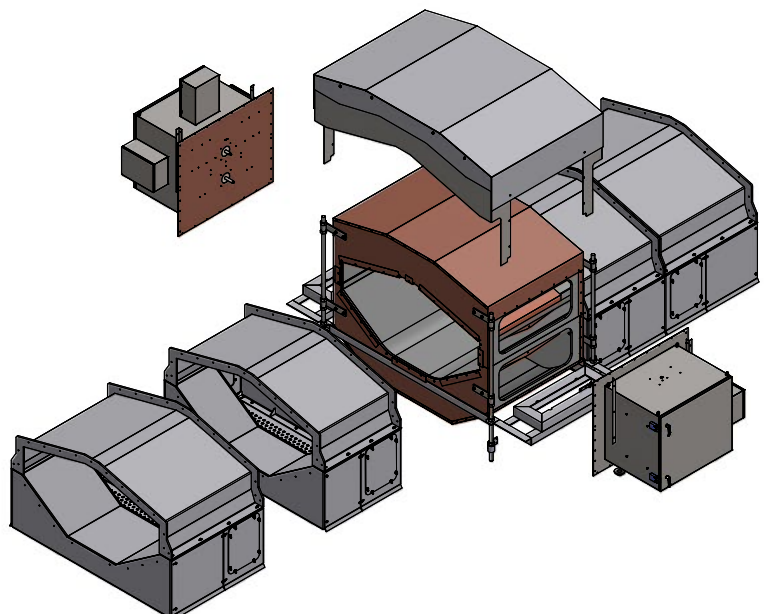

Figure 5 - Isometric view of MR sensor major design components.

As is typical for MR sensor installations, the sensor was installed during a scheduled 12-hour shutdown. As a result of COVID travel restrictions, installation was done by KMP personnel at the remote direction of NextOre personnel located in Sydney, Australia.

The sensor aperture dimensions are designed to safely accommodate the ore and achieve a fill factor, calculated as the cross-sectional area of the ore divided by the cross-sectional area of the antenna, of between 10-25%. The design features an opening size larger than the diameter of the largest expected particle size to pass through, resting on top of an otherwise fully loaded belt, without making contact with the sensor. There are no restrictions on the distance between the sensor and the surface of the ore, no restrictions on particle size or moisture content of the ore.

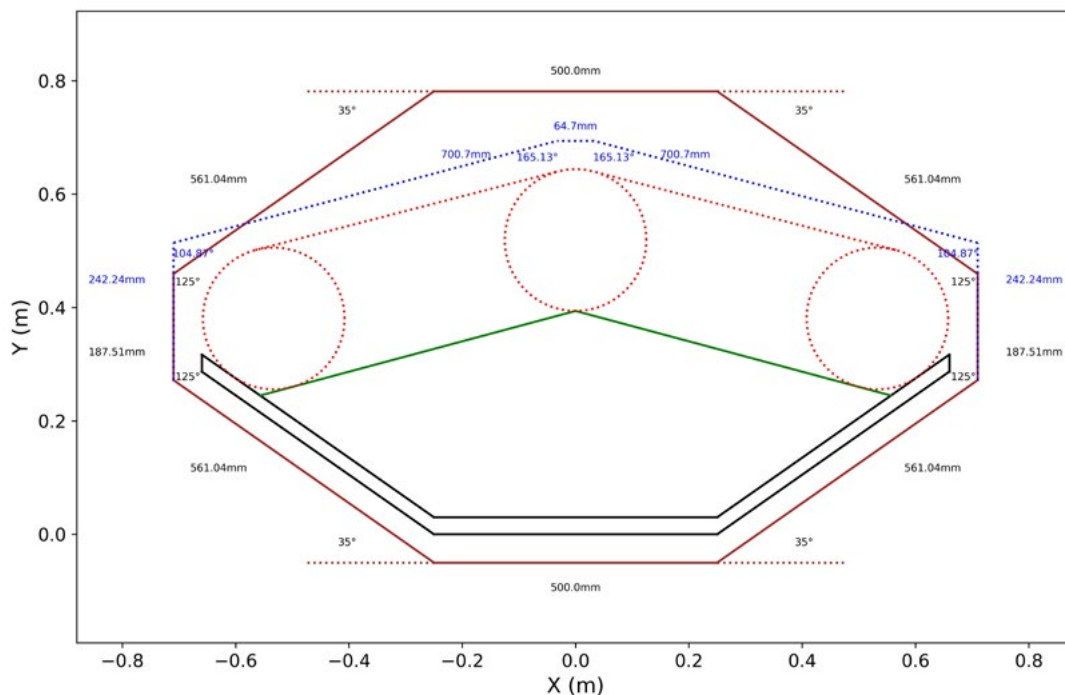

Figure 6 - MR Sensor typical cross-section. Red solid line shows minimum aperture design size.



Considerations for BOS Using Mineralogical Grade Sensing

MRAs measure mineralogical content, typically of a single mineral per analyser. Therefore, for measurement by MRA to be suitable for use in BOS either:

- a) the target mineral or minerals must represent substantially all of the copper bearing minerals in the stream, or
- b) the proportions of the target mineral to total copper grade must be sufficiently well understood and reliable in occurrence.

In the KMP Sulphide circuit, chalcopyrite is the dominant copper bearing mineral, hosting over 90% of the copper in the mill feed. The feeds to the other two circuits at Kansanshi, namely Mixed and Oxide, contain a wide range of copper minerals with variable proportions of primary and secondary copper sulphides as well as copper oxides and silicates. Consequently, use of the MRA tuned for chalcopyrite measurement is only suitable at Kansanshi for primary Sulphide ore.

Effective BOS outcomes rely implicitly on the effectiveness of mining and geological functions to separate ore types ahead of the crusher feed points for the respective processing circuits. This reliance on upstream ore assignment is not dissimilar to the three processing stream configuration of the processing plant, as each stream is optimised for recovery of the mineralogy of the respective ore types.

MRA Safety

Interlocks are fitted to all high voltage areas to ensure personnel safety, and all accessible areas adjacent to the conveyor belt have radiofrequency field strength well below public exposure limits as defined in (Australian Radiation Protection and Nuclear Safety Agency (arpansa), 2021) The sensor does not use ionising radiation.

No additional site-specific safety controls were required beyond those which are embedded in the MRA.

Diverter

A hydraulically actuated rock box diverting chute was custom designed for the application by KMP and the existing chute following CV1201 was modified to accommodate the change. The actuation time of the hydraulic mechanism is approximately 2 seconds. After moving from the “Product” position to the “Reject” position, several seconds elapse while a layer of hung-up rock accumulates to form an autogenous layer. The autogenous layer then reports to the Product belt when actuation is reversed. (A video of the diverter test can be accessed at <https://www.youtube.com/watch?v=vRLBnGgNmm4>)

Sensor / Diverter Control and Synchronization

A PLC integrated into the MRA electronics container sends signals directly to the diverter gate controller. The direct connection ensures that variable latency is not introduced from external systems and ensures correct timing of pod diversion. A bypass switch controlled by the KMP DCS system allows the KMP control room to enable or disable sorting functionality and preserve the flexibility of the 3 KMP processing lines.

The average speed of the conveyor belt is 3.41m/s and is highly consistent. The standard deviation of belt speed is 0.12m/s. There are no other features which introduce variability into the time between sensor and diverter, such as transfer chutes or surge bins.

Synchronization between the sensor and the diverter was fine-tuned by plumbing a water spray over the conveyor after the MRA and integrating an electrical solenoid valve via the MRA PLC. Two signals were programmed into the PLC output, one to the solenoid valve and the second to the diverter controller. A zero second delay was programmed into the solenoid valve signal and a longer delay of approximately 15.7 seconds was initially programmed into the diverter delay, then adjusted such that material wetted by sprays during commissioning reports to the reject conveyor and dry material reports to the product conveyor. This accounts for the swing time and rock box autogenous layer accumulation time to be tested experimentally to have the most precise separation of material by pod. (A video of the MRA/diverter synchronization spray tests can be accessed at <https://youtu.be/j3mSk2oUmLE>)

VALIDATION TESTING

Validation testing is undertaken firstly to confirm the sensor is measuring both accurately and precisely and secondly to check that the full BOS system is operating effectively and as designed.

Sensor accuracy (the difference between the measured value and the true value) is tested by conducting measurements of samples which are representative of feed and comparing these measurements to assays of the same samples.

Sensor precision (consistency or reproducibility of measurements) is tested by performing repeated measurements of the same samples and characterizing the standard deviation of the measurement. This test is also used to determine the lower detection limit of the sensor, which is the 3-sigma, or 99 percentile, value above zero.

A separate type of test is necessary to evaluate overall system functionality and ensure subsystem are operating properly and synchronised with the other components of the system. The separation of material by grade using BOS is statistically impossible to achieve accidentally, but the grades of the two streams can be relatively straightforward to confirm. This can be done through sampling and assaying of the streams by laboratory analysis, or using a method pioneered by Kansanshi by campaign processing of a test reject stockpile. This validation program for the Kansanshi BOS system, as described below, is believed to be truly novel and the successful results achieved are believed to be unprecedented at this scale.

Static Testing

One or more pre-characterised samples are measured repeatedly to characterise MR measurement precision and accuracy.

Procedure

MRA measurements are produced for each sample and assays are performed on subsamples thereof. The MRA produces a measurement for 100% of the sample material in each case, whereas standard assay techniques are performed on samples typically of only a few grams. Proper sampling and assaying methodologies must be maintained to minimize error introduced as a result of measuring different samples.

To reduce the potential for error, ore samples were crushed finely and pre-characterized by XRF assay at the KMP site laboratory.

MRA sample measurement procedure

Each sample was made up of three bags which were laid out along the 1.1m length of the sensor to approximately replicate typical ore loading of the sensor. While the conveyor belt was stopped, and with a NextOre representative either remotely or physically present, the MRA was disabled and samples positioned manually inside the MRA sensor opening area. The MRA was then restarted and operated for approximately five minutes to collect measurements of the sample in 4 second intervals for approximately 300 individual measurements per sample.

Static Testing Results

Figure 7 shows results of static measurements for accuracy with an R2 value of 0.98.

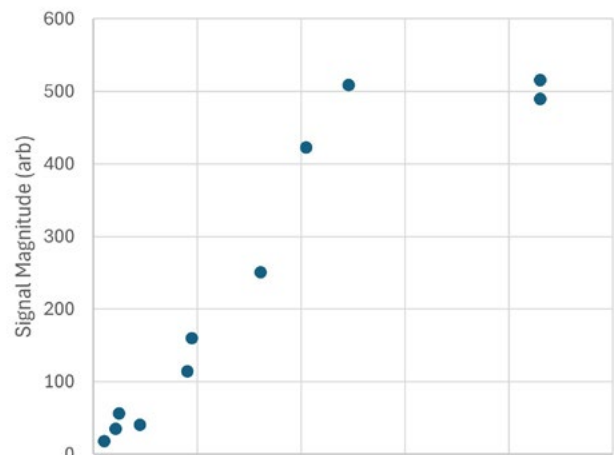

Figure 7 - Measurement of signal magnitude for crushed ore samples compared to the KMP metallurgical laboratory.

Figure 8 shows signal magnitude of MRA measurements over time during the sample testing program. Data in the chart is made up of successive 4-second measurement intervals and the observed noise gives measurement precision. When converted from magnitude to copper grade percentages, this grade variability represents a 1-sigma standard deviation of 0.014% copper and a 0.045% copper lower detection limit.

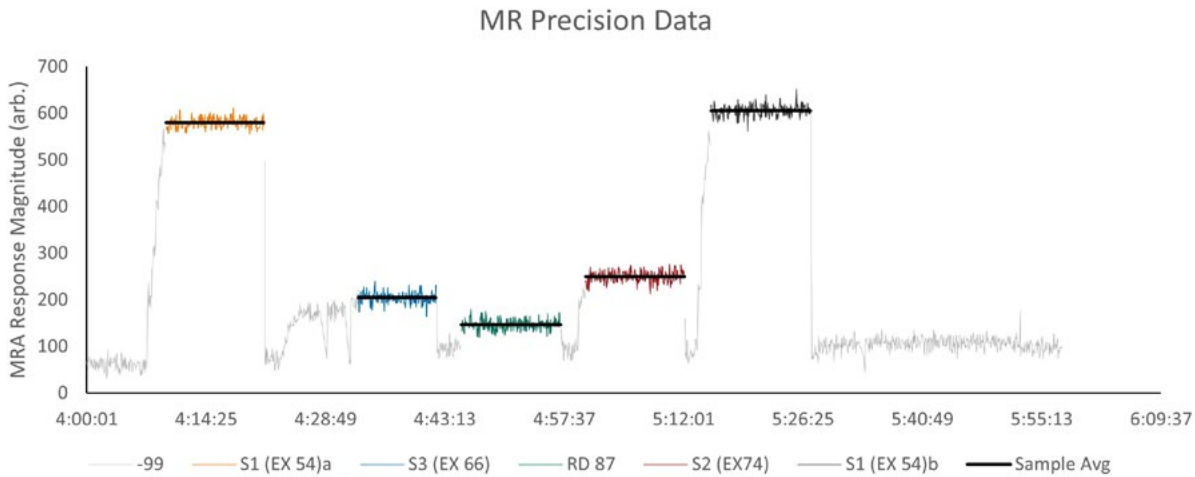

Figure 8 - Example measurement of signal magnitude for crushed ore samples over time for calculation of precision. Note these tests were performed with a layer of accumulated fine ore at the bottom of the sensor, leading to a residual signal magnitude observed between sample measurements.

Metallurgical reconciliation

Further validation was performed by comparing daily average copper grades as calculated by the MRA with metallurgical reporting balances for the primary copper sulphide feed line. As shown in Figure 1, the sampling point for metallurgical sample collection is located at the cyclone overflow following the primary sulphide comminution circuit. The coarse ore stockpile ahead of the SAG mill fluctuated in size up to 70,000 tonnes, or just over 1 day of full feed to the circuit. This fluctuation could not be reliably monitored and calculated, and consequently the comparison of MRA grades to metallurgical balances can only be used roughly, and only over a sufficiently large time scale.

Figure 9 shows 16 days of 24-hour average grade comparisons between MRA grade readings and KMP metallurgical reporting using assays of samples collected from the cyclone overflow sampling point.

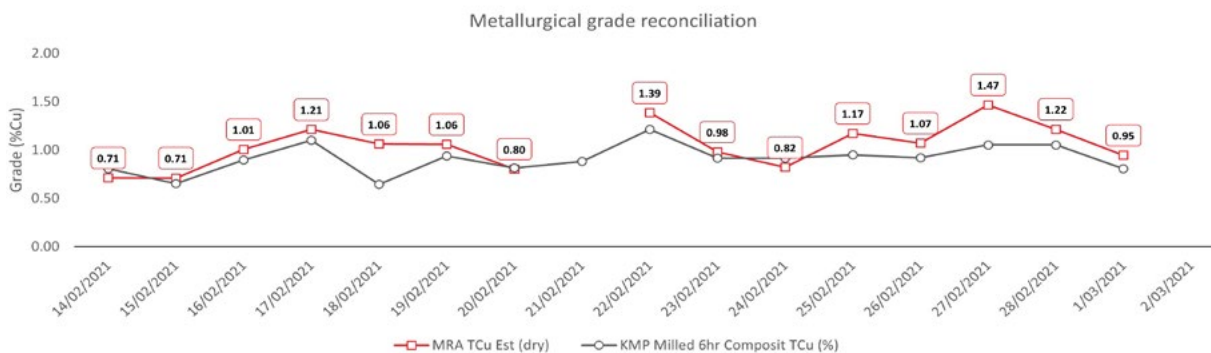

Figure 9 - MRA grade measurements versus KMP metallurgical sampling and assays for 24-hour average periods. Maintenance occurred on 21 February and therefore no MRA data was available for the day.



A well-designed validation program will demonstrate clearly and simply the equipment capability and the bulk sorting separation efficiency. Application of bulk ore sorting is a significant project and validation results need to stand up under scrutiny.

Dynamic testing

KMP applied a novel methodology for full-scale validation procedure not seen at any other operation. BOS activities were undertaken for a period of approximately two weeks prior to 19 May 2021. During this period of time, a diverter cut-off grade of 0.20% copper was applied and an estimated 10,000 tonnes of reject material reported to the reject stockpile. (Figure 10) Average grade for this reject material as reported by the MRA was 0.16% copper.

During a campaign of -1 hour and 45 minutes, the BOS functionality was disabled and 5,000 tonnes of the rejected material was fed back to the gyratory crusher of the primary sulphide processing circuit, making up the entirety of the feed material. The coarse ore stockpile was drawn down in advance of the campaign such that the reject material would report without any delay and with minimal cross-contamination to the grinding stage of the primary sulphide circuit.

Samples were collected every five minutes for the duration of the campaign from the cyclone overflow sampling point of the grinding circuit (refer to Figure 1). Samples were assayed for total copper content. The chart below shows measurements collected by MRA and corresponding sample assay grades for the campaign period, as well as the periods immediately preceding and following the campaign.

Figure 11 shows 24 hours of grade data from MRA along with sample assay data for 19 May during the validation campaign. Sample assays from the cyclone overflow decline for the duration of the campaign and reaching a minimum grade of 0.17%Cu before climbing again after completion of the campaign.



Figure 10 – Approximately 10,000 tonnes of BOS reject material accumulated at KMP and used for validation testing program.

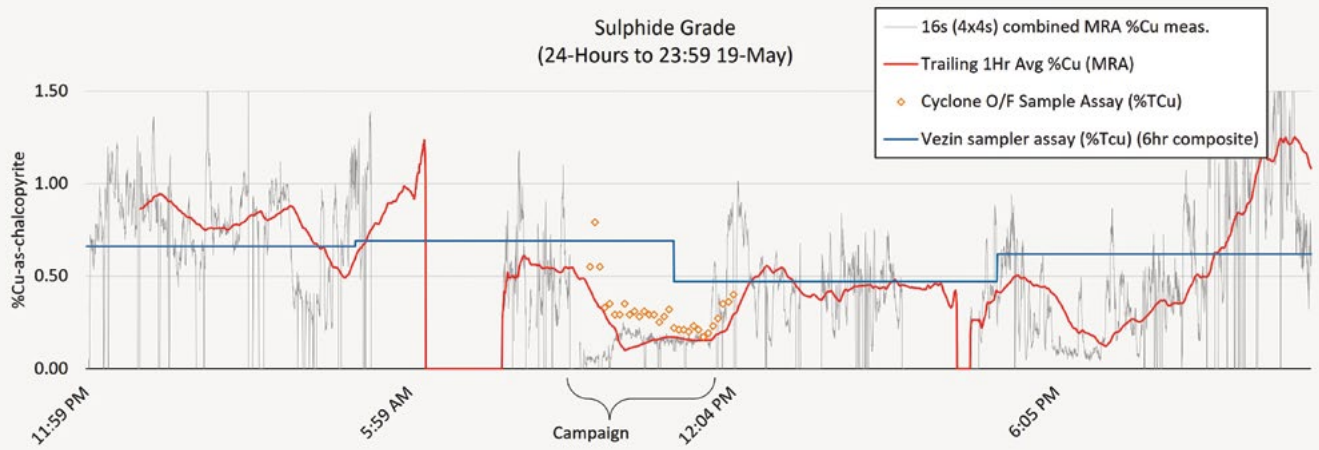

Figure 11 - MRA trailing average grades (16 seconds and 1 hour) and sample assay grades.



BULK SORTING RESULTS

Significant heterogeneity was observed in MRA grade measurement data at the Kansanshi mine, supporting expectations based on the complex geological setting of the ore. Operational mixing inherent in the Kansanshi operation is minimal and represents an ideal setting for BOS. Ore is loaded to trucks by shovels in the bench and tipped directly to the crusher feed pocket, generally with no rehandle although stockpiling does occur on occasion. As a result, heterogeneity is preserved and strong bulk ore sorting results can be achieved with installation of the BOS system after the primary crusher.

Figure 12 shows typical grade fluctuations over a 24-hour period. An example, theoretical sorting cut-off grade example is overlaid along with calculation of mass and metal recovery. MRA grade measurements were observed to frequently fluctuate at Kansanshi below 0.10% and above 2.50% copper within a matter of hours.

Mass recovery and metal recovery of BOS can be adjusted by changing the BOS diverter cut-off grade. To illustrate the range of potential bulk ore sorting outcomes, MRA grade data is collected for a period and a range of sorting cut-off grades applied, with mass and metal recoveries calculated for the data set. This allows the BOS to be optimised continually to suit the characteristics the surrounding operation.

Results of this analysis for a one-month aggregate period are shown in Figure 13.

The results are contextualised by comparing with “Excellent”, “Good”, “Moderate” and “Poor” results observed by NextOre either in other BOS installations or in heterogeneity study results for other mining projects and mining operations conducted previously by NextOre and CSIRO.

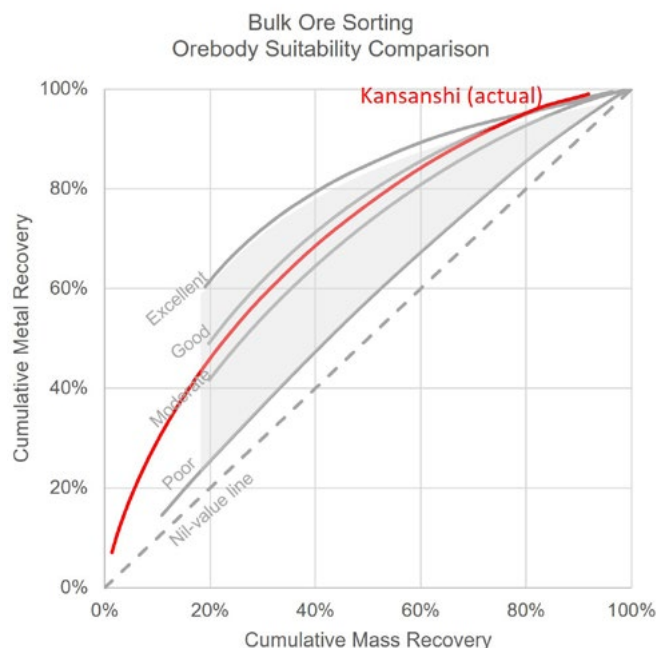

Figure 13 - Calculated range of BOS mass and metal recovery scenarios achievable at KMP by varying BOS diverter cut-off grade for November 2022 aggregated MRA measurements.

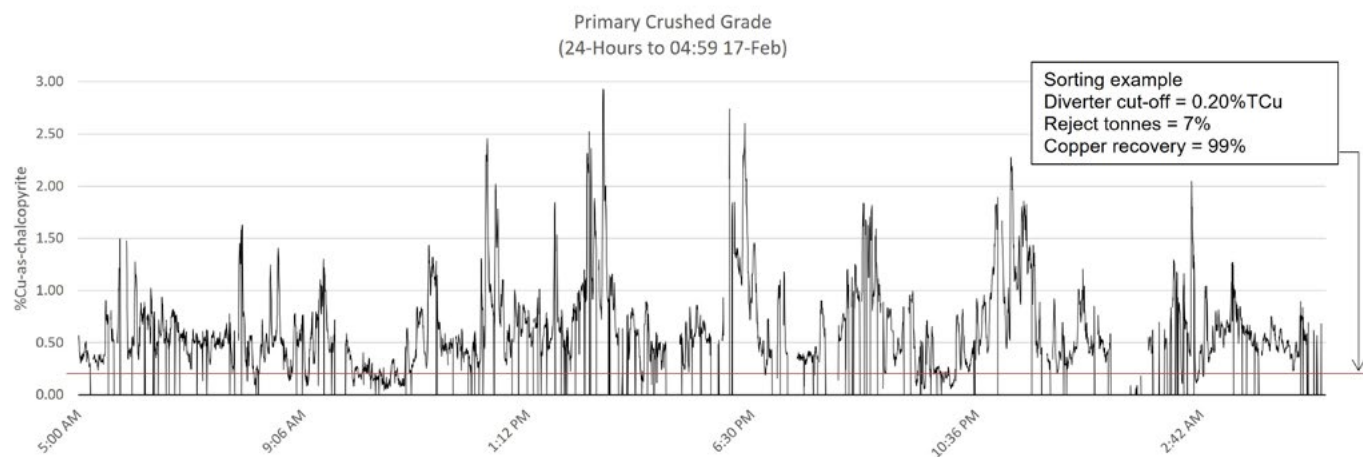

Figure 12 - Time series MRA grade data showing example of typical grade fluctuation observed over a 24-hour period. Note that the chart shows an average grade of 4x MRA measurements, each of 4 second intervals, to more easily visualise the data.



REFERENCES

Australian Radiation Protection and Nuclear Safety Agency (arpansa). (2021, Feb). *Standard for Limiting Exposure to Radiofrequency Fields - 100 kHz to 300 GHz; Radiation Protection Series S-1 (Rev. 1)*. arpansa. Retrieved from arpansa.gov.au

Duffy, K.-A., Valery, W., Jankovic, A., Holtham, P., & Valle, R. (2015). *Bulk ore sorting for preconcentration: what, how, and why?* Santiago: Procemin.

First Quantum Minerals Ltd. (2023). *2022 Annual Report*. Vancouver: First Quantum Minerals Ltd.

Gray, D., Lawlor, M., & Briggs, A. (2020). *Kansanshi Operations | NI 43-101 Technical Report*. Vancouver: First Quantum Minerals Ltd.

Humphreys, D. (2020). *Mining productivity and the fourth industrial revolution*. Mineral Economics.

An aerial photograph of a mining operation, showing various pieces of heavy machinery, conveyor belts, and large piles of earth and rock. A prominent red diagonal stripe runs from the top-left corner towards the center-right of the image. The text 'NEXT ORE' is positioned in the upper right quadrant, with a red diagonal line striking through the 'X' in 'NEXT' and the 'O' in 'ORE'.

NEXT
ORE

nextore.com.au